

ONE PIECE HEAVY DUTY 6' X 12' FLOATING DOCK

Kit Name: 6x12 Floater

KIT INCLUDES	QTY
INSIDE CORNER, HL-IC	4
JOIST ANGLE, HL-A	8
FLOATS, F-2416	4
ALL HARDWARE, GALV.	
BUILD/INSTALL MANUALS	
KIT PRICE	\$ 599.00
APPROX CUSTOMER WOOD COST \$150.00	
KIT OPTIONS:	
RUB RAIL/ CORNER BUMPERS	117.00
VINYL DECKING	563.00
DELUXE VINYL DECKING (INCL. FACIA MATL)	636.00
PIPE HOLDER KIT (2)	34.00
TIE OFF MALES TEES (2)	18.00
SPUD PIPES, 10' LG (2)	150.00

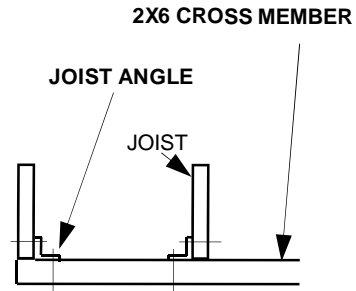

SECTION A-A

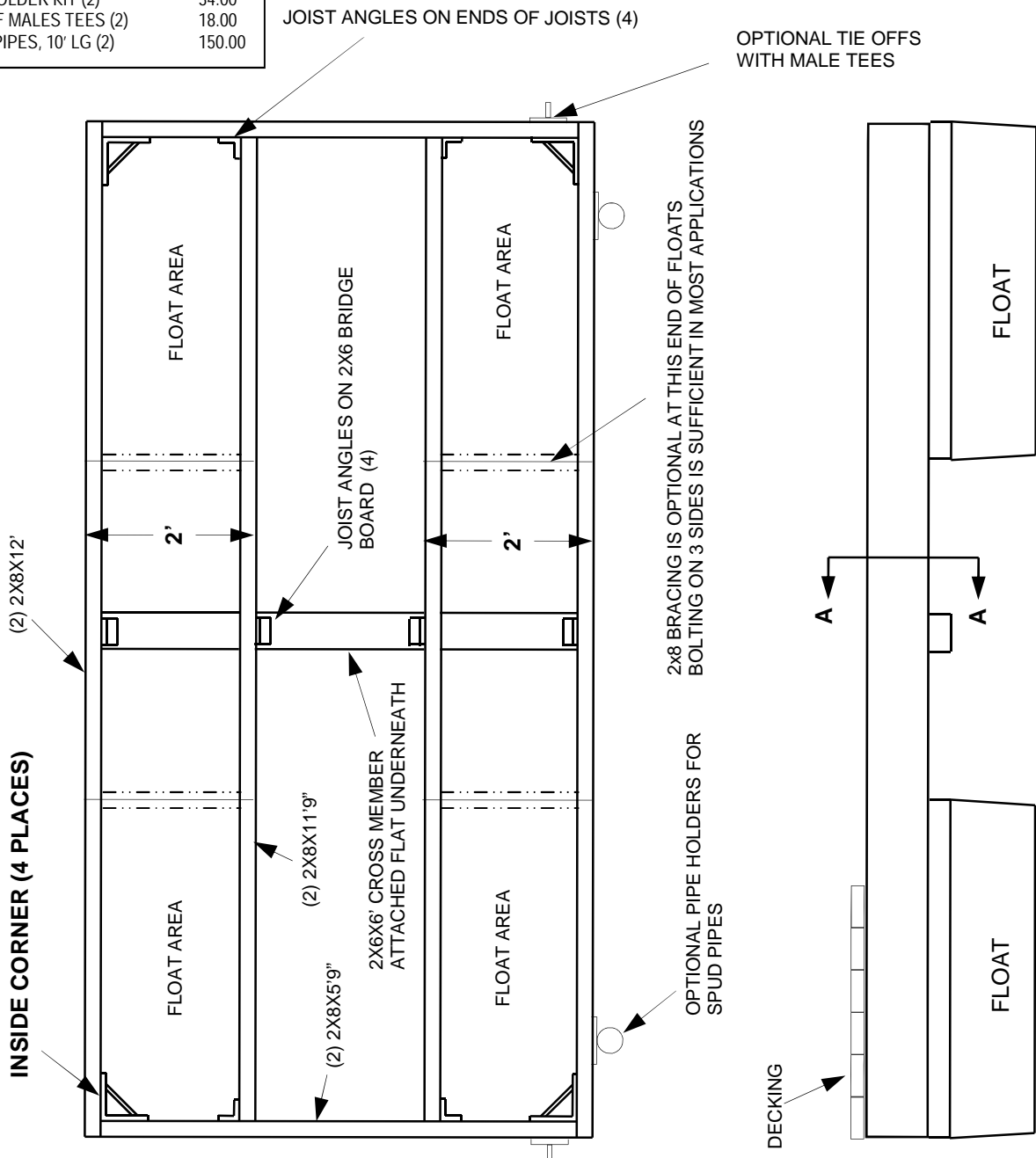

OPTIONAL TIE OFFS WITH MALE TEES

20' STRAIGHT PIER DESIGN—POSTS INSIDE

Kit Name: 20' Fixed Pier With Inside Posts

The most popular design for a straight pier has the support posts under the dock where they are not in the way of boats or fishing—not to mention that the overall appearance is more esthetically pleasing since the pipe is barely visible. The drawing below shows typical parts for a typical fixed pier recreational dock.

NO DECKING MATERIAL SHOWN

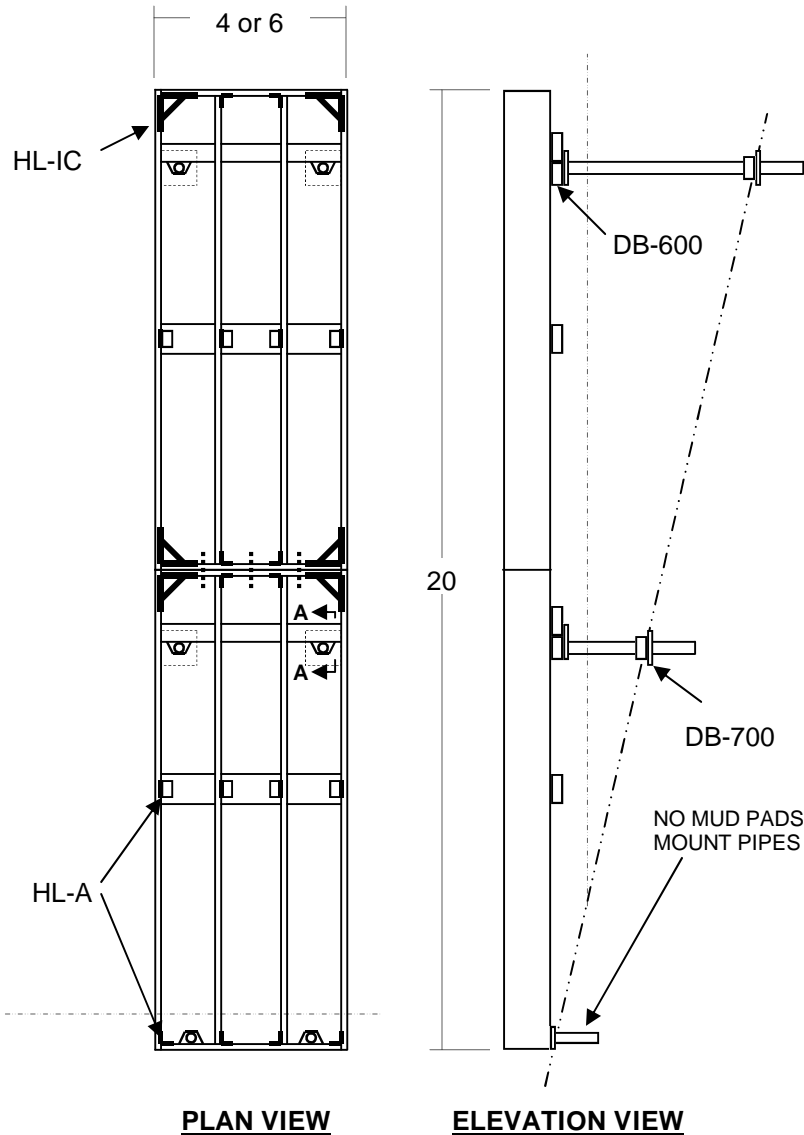

KIT INCLUDES	QTY
INSIDE CORNER, HL-IC	6
JOIST ANGLE, HL-A	18
SIDE BRACKET, DB-600	6
MUD PAD, DB-700	4
ALL HARDWARE, GALV.	
BUILD/INSTALL MANUALS	
KIT PRICE	\$ 385.00
APPROX CUSTOMER WOOD COST \$220.00	
KIT OPTIONS:	
RUB RAIL/ CORNER BUMPERS	136.00
VINYL DECKING	667.00
DELUXE VINYL DECKING (INCL. FACIA MATL)	805.00
SUPPORT PIPES, 7' LG (5)	250.00

SPECIFICATIONS	
MAIN FRAME & JOISTS	2 X 8
CROSS MEMBERS	2 X 6
DECKING	OPTIONAL
SUPPORTS	2" SCH 40 GALV PIPE
FACIA	OPTIONAL
RUB RAIL	OPTIONAL
CORNER BUMPERS	OPTIONAL
SIDE BRACKETS, MUD PADS	

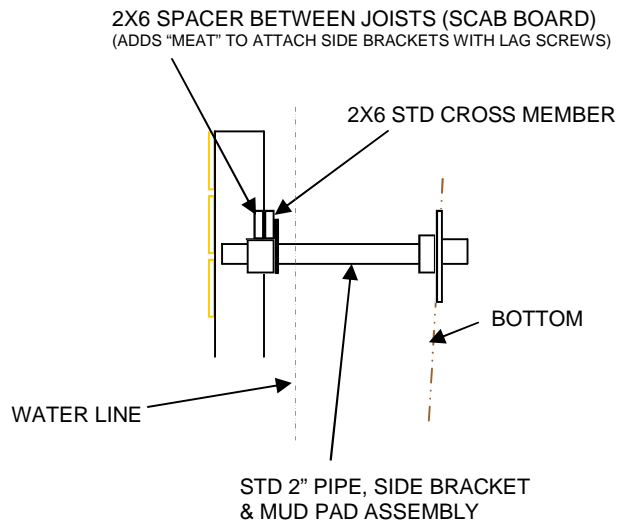

SECTION A-A

LIGHT DUTY 24' STRAIGHT PIER DESIGN

Kit Name: 24' Fixed Pier With Outside Posts

THIS LIGHTER DUTY DESIGN USES JOIST ANGLES INSTEAD OF INSIDE CORNERS

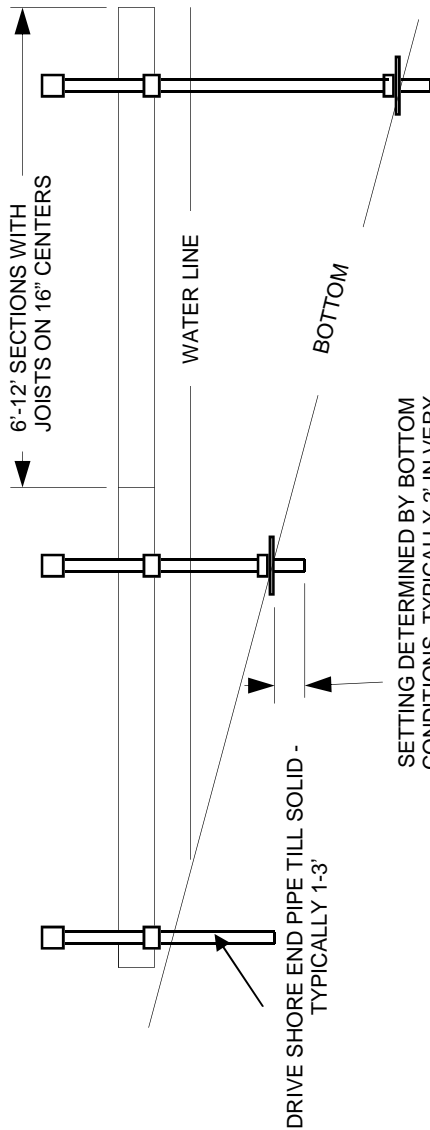
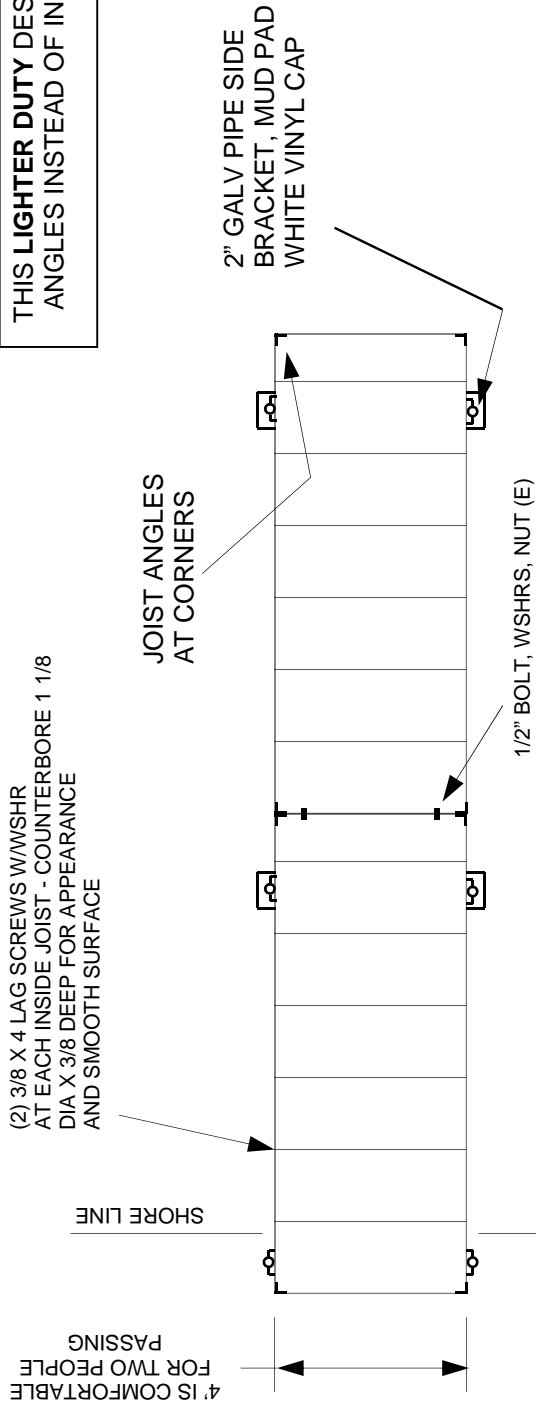

1. ALL SIDE BRACKETS & MUD PADS HAVE A SETSCREW FOR VERTICAL ADJUSTMENT.
 2. PIPES ARE NORMALLY CUT AFTER INSTALLATION TO SAME HEIGHT AND CAPPED.

KIT INCLUDES	QTY
JOIST ANGLE, HL-A	8
SIDE BRACKET, DB-600	6
MUD PAD, DB-700	4
ALL HARDWARE, GALV.	
BUILD/INSTALL MANUALS	
KIT PRICE	\$ 280.00
APPROX CUSTOMER WOOD COST \$225.00	
KIT OPTIONS:	
RUB RAIL/ CORNER BUMPERS	170.00
VINYL DECKING	782.00
DELUXE VINYL DECKING (INCL. FACIA MATL)	920.00
SUPPORT PIPES, 7' LG (5)	250.00

OTHER COMMON DOCK CONFIGURATIONS

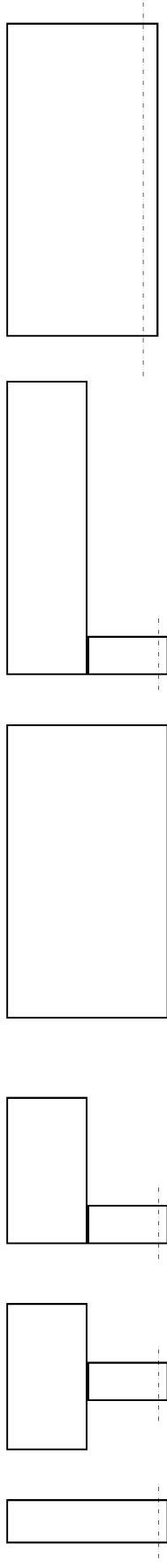

STRAIGHT
PIER

SMALL
T-SHAPE

SMALL
L-SHAPE

LARGE
T-SHAPE

WIDER
L-SHAPE

LARGER
PATIO
DOCK

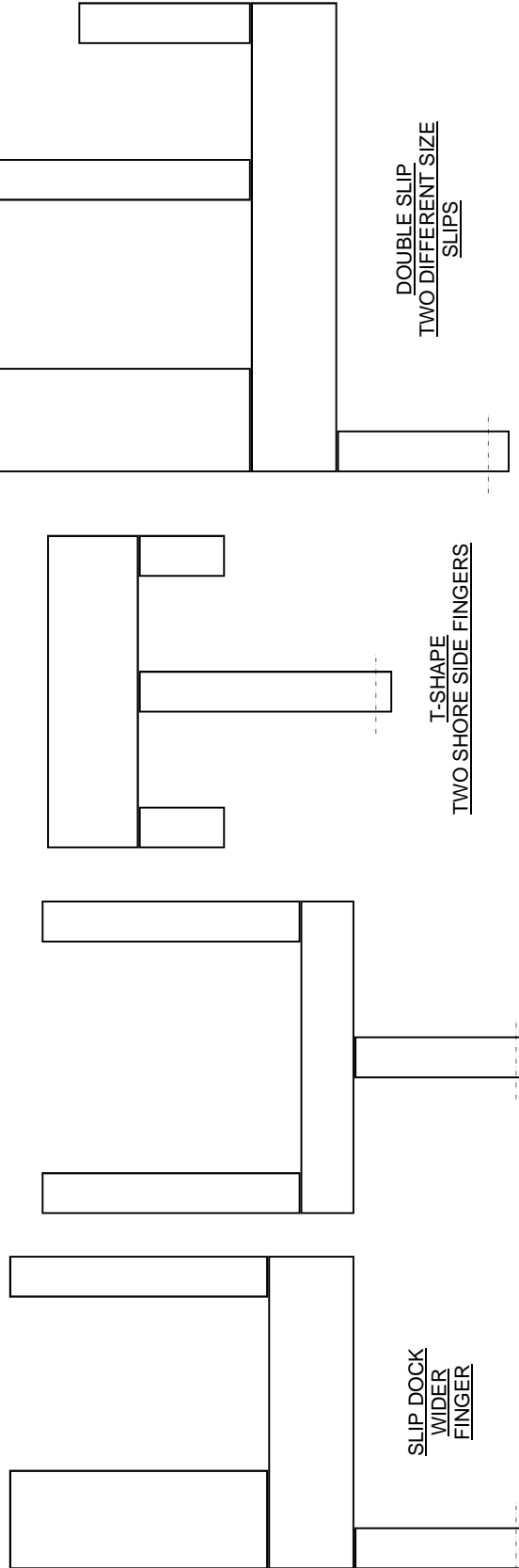

SLIP DOCK
WIDER
FINGER

SLIP DOCK

I-SHAPE
TWO SHORE
SIDE FINGERS

DOUBLE SLIP
TWO DIFFERENT
SIZE
SLIPS